



stifflex®

MADE IN ITALY



2024



**stifflex**<sup>®</sup>  
MADE IN ITALY

An innovative system patented by Giuliano Mazzuoli, the designer and founder of the company, is at the foundation of the new **Stifflex** collections that are born from the talent and the creativity of a number of young graphic designers who by giving a free outlet to their fantasies have conceived the covers for the new collections of notebooks in the *Urban*

*Series, Vintage Surfing, Surfside, Art, Calaca, Scrubbles, Underground, Cocktail, Camouflage, Historical Notes, Pop, Campbook, Fluo Love, Fluo Marilyn, Wild Pearl, Mrs. Crocodile, Animals Smile, Flora, New Fresh Fruit, Custom Garage, Gasoline, Container Notes, The Wall, Alias, VHS, Musicassette, Vinyl, Diversity, Sweet, Paint, PRISMA Colors and artWORK collections.*



▶ Hard/flexible cover

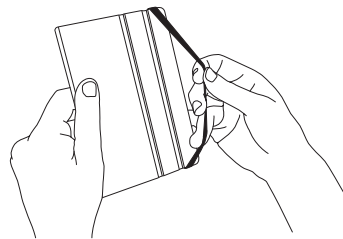

▶ Elastic closure

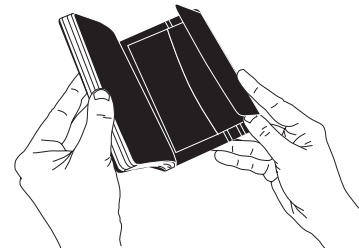

▶ Pocket/Bookmark



▶ Document holder pocket

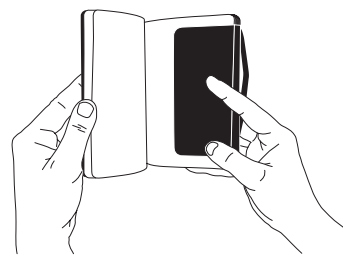

▶ Bookmark



Every notebook comes with a ruler/bookmark

## FORMATS

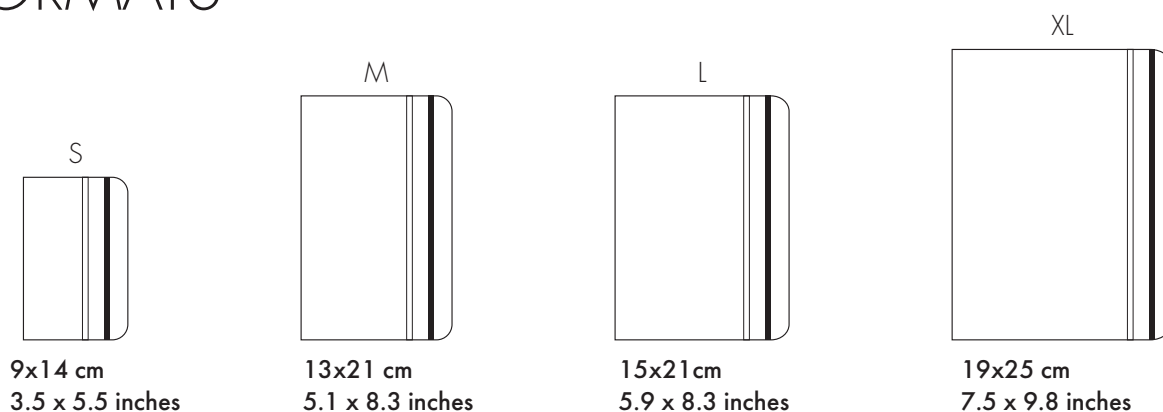

The notebooks are made with uncoated ivory-colored paper of 80 g. in the 9x14 cm, 13x21 cm, 15x21 cm and 19x25 cm formats.

- 9x14 cm: comprised of 144 pages of which 96 are lined, 32 are blank, and 16 are graphed.
  - 13x21 cm 15x21 cm, 19x25 cm: comprised of 192 pages of which 144 are lined, 32 are blank, and 16 are graphed.
- The graphed pages are perforated and easily detachable.  
The product is certified FSC<sup>®</sup>.

## DISPLAYS

The *Stifflex* displays are supplied already assembled and are made in alveolar cardboard in a havana brown color so that the entire production maintains unaltered the standards of environmental sustainability and respect for the environment in which the company as always based its policies.



EXPO1 S

Counter display (9x14 cm)  
**Measurements:** cm 34x29x27  
**It can contain:** 36 pieces, 9x14 cm



EXPO2 M

Counter display (13x21 cm and/or 15x21 cm)  
**Measurements:** cm 52x29x34  
**It can contain:** 36 pieces, 13x21 cm and/or 15x21 cm



EXPO3 L

Floor display  
**Measurements:** cm 60x25x185  
**It can contain:** 100 pieces, 9x14 cm  
60 pieces, 13x21 cm  
40 pieces 15x21 cm  
30 pieces 19x25 cm  
230 assorted pieces in total



# ANIMALS SMILE



# ART



# ART





# ART

---

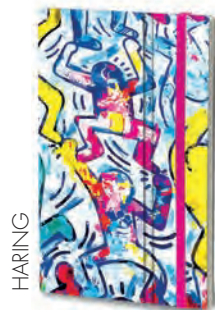

HARING

231M (13x21)



BASQUIAT

232M (13x21)



WARHOL

233M (13x21)

# CALACA

---



GREY

050M (13x21)



OCHRE

052M (13x21)



INDIGO

053M (13x21)



CHARCOAL

054M (13x21)



YELLOW

118M (13x21)



AQUAMARINE

119M (13x21)

# CAMOUFLAGE

---



GREY

010M (13x21)



CAMO

011S (9x14)  
011M (13x21)



FUCHSIA

012S (9x14)  
012M (13x21)

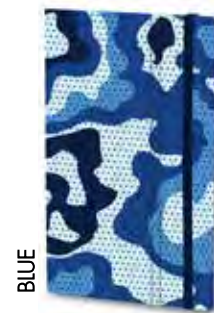

BLUE

013S (9x14)  
013M (13x21)



# CAMPBOOK

---

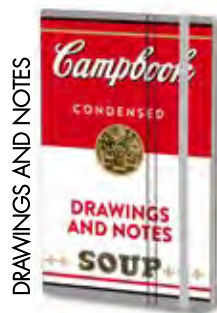

DRAWINGS AND NOTES

134S (9x14)  
134M (13x21)



SKETCHES AND IDEAS

135S (9x14)  
135M (13x21)



THOUGHTS AND WORDS

136S (9x14)  
136M (13x21)



LOVE AND POETRY

137M (13x21)

# CHESS

---



BLUE

018S (9X14)  
018M (13X21)



MULTICOLOR

019S (9X14)  
019M (13X21)



FUSCHIA

020S (9X14)  
020M (13X21)

# COCKTAIL

---



NEGRONI

126M (13x21)



MARTINI

127M (13x21)



DAQUIRI

128M (13x21)



MOJITO

129M (13x21)



# CUSTOM GARAGE



# FLORA



# FLUO LOVE





# FLUO MARILYN



GREEN - BLUE

159M (13x21)



YELLOW - GREEN

160M (13x21)



ORANGE - FUCHSIA

161M (13x21)

# FRESH FRUIT



PINEAPPLE

014S (9x14)  
014M (13x21)



BANANA

015S (9x14)  
015M (13x21)



APPLE

016S (9x14)  
016M (13x21)



PEAR

017S (9x14)  
017M (13x21)

# NEW FRESH FRUIT



PINEAPPLE

074L (15x21)



STRAWBERRY

076L (15x21)

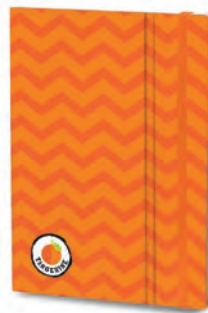

TANGERINE

077L (15x21)

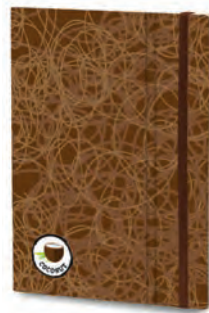

COCONUT

078L (15x21)

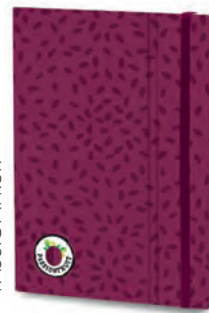

PASSIONFRUIT

079L (15x21)





# GASOLINE

---



# HISTORICAL NOTES

---



# HISTORICAL NOTES

---

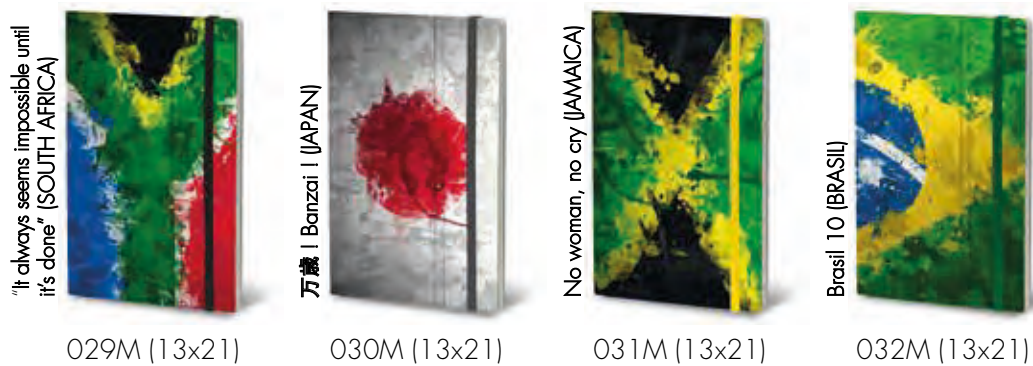



# HISTORICAL NOTES



033M (13x21)



034M (13x21)



035M (13x21)



036M (13x21)



101M (13x21)

# ICON



068M (13x21)



069M (13x21)



070M (13x21)

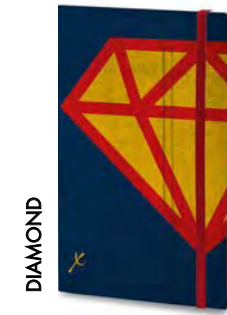

071M (13x21)



072M (13x21)



073M (13x21)

# MRS. CROCODILE



062S (9x14)

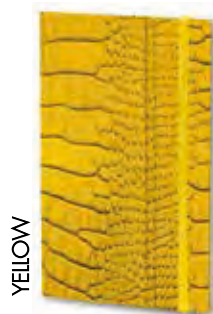

063S (9x14)  
063M (13x21)



064S (9x14)  
064M (13x21)



065S (9x14)  
065M (13x21)



066S (9x14)  
066M (13x21)



067S (9x14)  
067M (13x21)



# MUSICASSETTE

---



YELLOW TAPE

188S (9x14)



ORANGE TAPE

189S (9x14)



RED TAPE

190S (9x14)



BLUE TAPE

191S (9x14)

# MUSICASSETTE

---



BLACK HQP

192S (9x14)



BLACK CASSETTE

193S (9x14)



BLACK STEREO

194S (9x14)



BEIGE TAPE

195S (9x14)

# PAINT TRANSCENDENCE

---



SHIVA

219M (13x21)

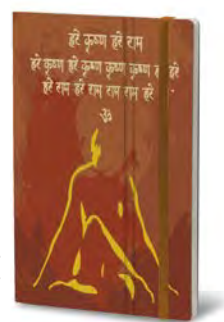

YOGA

220M (13x21)





# POP

---



SPACESHIP

037M (13x21)



I LOVE YOU!

038M (13x21)



WOMAN

039M (13x21)



MIX

040M (13x21)



ZOOM

041M (13x21)

# POP

---



BOOOOOOM!

042M (13x21)

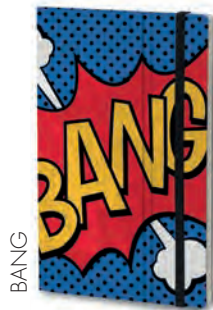

BANG

043M (13x21)

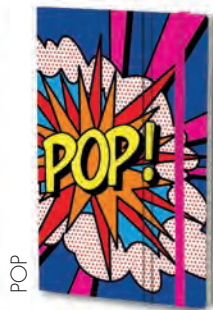

POP

130M (13x21)



WHITE LIPS

131M (13x21)

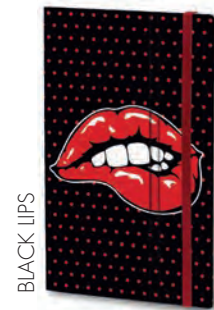

BLACK LIPS

132M (13x21)



WOW

133M (13x21)

# SCRUBBLES

---



HELLO

023S (9x14)  
023M (13x21)



ICON

024S (9x14)  
024M (13x21)



# SKULL

---

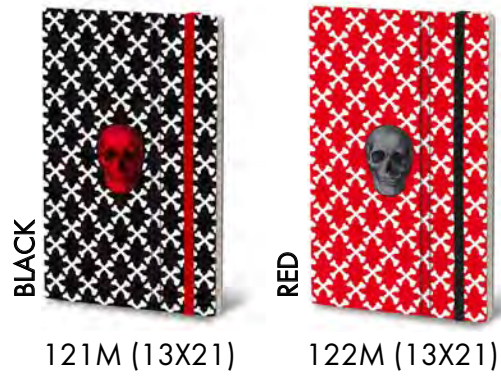

# SURFSIDE

---



# SWEET

---





# UNDERGROUND

---



STOCKHOLM

056S (9x14)  
056M (13x21)  
056XL (19x25)



BERLIN

057S (9x14)  
057M (13x21)  
057XL (19x25)



PARIS

058S (9x14)  
058M (13x21)  
058XL (19x25)

# UNDERGROUND

---



MADRID

059S (9x14)  
059M (13x21)  
059XL (19x25)

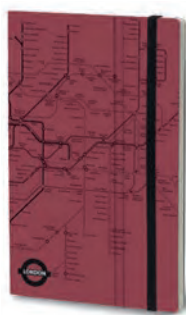

LONDON

060S (9x14)  
060M (13x21)  
060XL (19x25)



MILAN

061S (9x14)  
061M (13x21)  
061XL (19x25)

# UNDERGROUND - New York

---

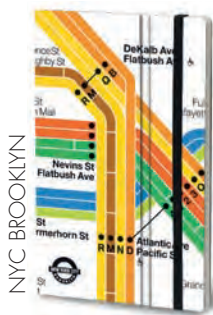

NYC BROOKLYN

123S (9x14)  
123M (13x21)



NYC MANHATTAN

124S (9x14)  
124M (13x21)



NYC VINTAGE

125S (9x14)  
125M (13x21)





# URBAN SERIES



093M (13x21)



094M (13x21)



095M (13x21)



096M (13x21)

# URBAN SERIES

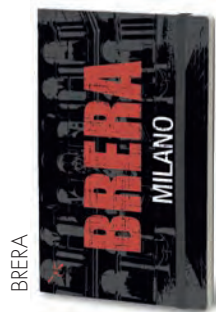

097M (13x21)



098M (13x21)



099M (13x21)



100M (13x21)

# VHS

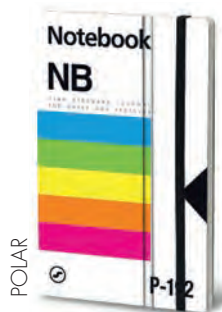

181M (13x21)



185M (13x21)



187M (13x21)

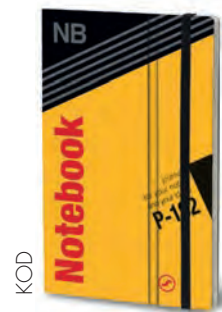

182M (13x21)



183M (13x21)



184M (13x21)



186M (13x21)



# VINTAGE SURFING - CALIFORNIA

---



CALIFORNIA BLUE

001S (9x14)  
001M (13x21)



CALIFORNIA RED

002S (9x14)  
002M (13x21)



CALIFORNIA BLACK

003S (9x14)  
003M (13x21)

# VINTAGE SURFING - ADVENTURE

---



ADVENTURE ORANGE

004M (13x21)



ADVENTURE RED

005S (9x14)  
005M (13x21)



ADVENTURE GREEN

006S (9x14)  
006M (13x21)

# VINTAGE SURFING - SURF RIDER

---



SURF RIDER BLUE

007S (9x14)  
007M (13x21)



SURF RIDER RED

008S (9x14)  
008M (13x21)



SURF RIDER ORANGE

009S (9x14)  
009M (13x21)



# VINYL - 45 r.p.m.

---

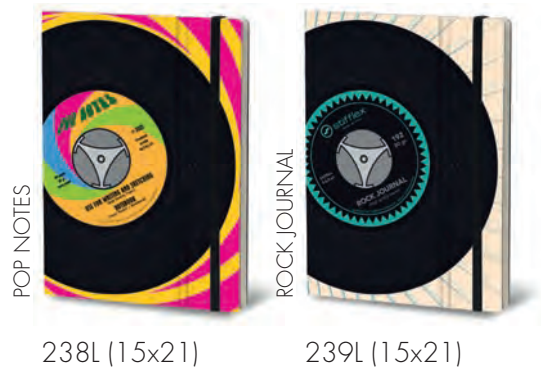

# WILD PEARL

---



# WILD PEARL

---







The name for the new **Stiff** collection, with its essential and harmonious design, comes from the shortening of the name *Stifflex*. It's a more classic version of our notebook that enhances the value of tradition and enriches it with new elements. A hard cover with a balanced shade and the inside pages either blank or lined are combined with an environmentally friendly pencil with an eraser made with recycled and recyclable material. Available in the *Basic* and *Leatherlike* collections, the notebooks in this line adapt perfectly to every occasion and above all are perfect for those who enjoy habits that respect values from other times.

## FORMATS

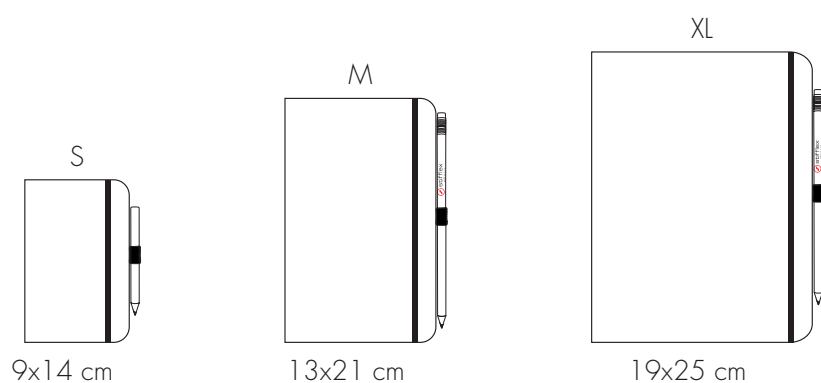

The notebooks in this collection are made with 80 g. uncoated white paper. They are available in the 9x14 cm, 13x21 cm, and 19x25 cm formats made up of 144 pages. Every notebook comes with a pencil and is FSC® certified.



# BASIC

## HARD COVER NOTEBOOK WITH PENCIL



Ruled sheets



BLACK	aR001S (9x14) aR001M (13x21) aR001XL (19x25)	RED	aR002S (9x14) aR002M (13x21) aR002XL (19x25)	BLUE	aR003S (9x14) aR003M (13x21) aR003XL (19x25)	YELLOW	aR004S (9x14) aR004M (13x21) aR004XL (19x25)
-------	--	-----	--	------	--	--------	--

Blank sheets



	bR001S (9x14) bR001M (13x21) bR001XL (19x25)		bR002S (9x14) bR002M (13x21) bR002XL (19x25)		bR003S (9x14) bR003M (13x21) bR003XL (19x25)		bR004S (9x14) bR004M (13x21) bR004XL (19x25)
--	--	--	--	--	--	--	--

# LEATHERLIKE

## HARD COVER NOTEBOOK WITH PENCIL



Ruled sheets



BLACK	aR005M (13x21)	BROWN	aR006M (13x21)	LIGHT BROWN	aR007M (13x21)	DOVE GREY	aR008M (13x21)
-------	----------------	-------	----------------	-------------	----------------	-----------	----------------

Blank sheets



	bR005M (13x21)		bR006M (13x21)		bR007M (13x21)		bR008M (13x21)
--	----------------	--	----------------	--	----------------	--	----------------



From the shortening of the name *Stifflex* come the new collection of **Flex** notebooks that are characterized by a flexible softcover in monochromatic shades that hold lined, blank, and squared pages in ivory paper inside. Available in six different pastel colors, the notebooks in this collection have a subdued and appealing look adapting themselves perfectly to brightening your day with a touch of originality.

## FORMAT

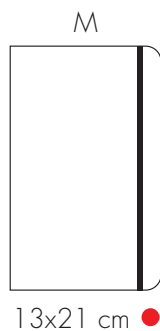

13x21 cm ●

*soft cover*

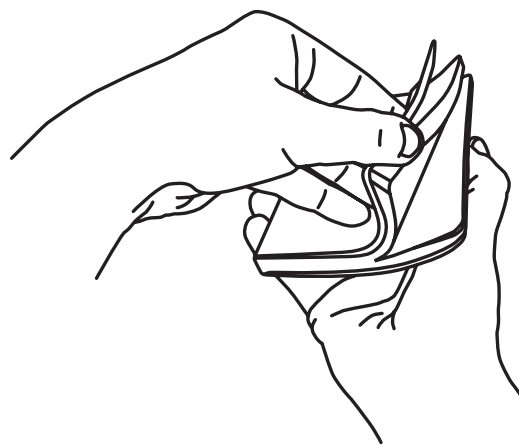

**SOFTCOVER**

The notebook is made with uncoated 80 gram ivory paper. It's available in the 13x21 cm format and composed of 192 pages of which 144 are lined, 32 are blank, and 16 are squared. The squared pages are perforated and can be easily detached. The product is FSC® certified.





# FLEX

SOFTCOVER NOTEBOOK

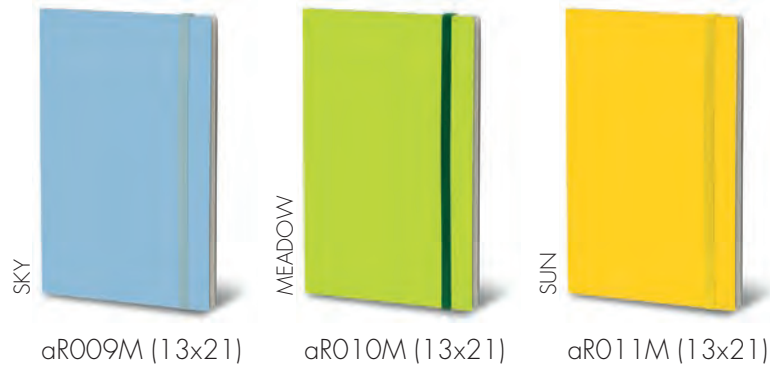

# FLEX

SOFTCOVER NOTEBOOK

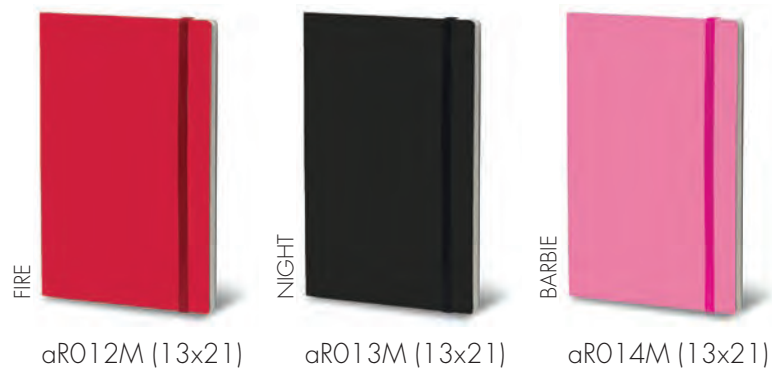

# COLOR NOTEBOOKS

w/Infinite Ballpoint pens





DRAW - COLOR - DESIGN

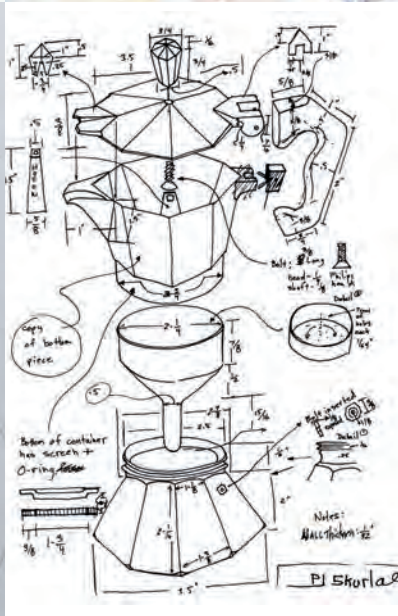
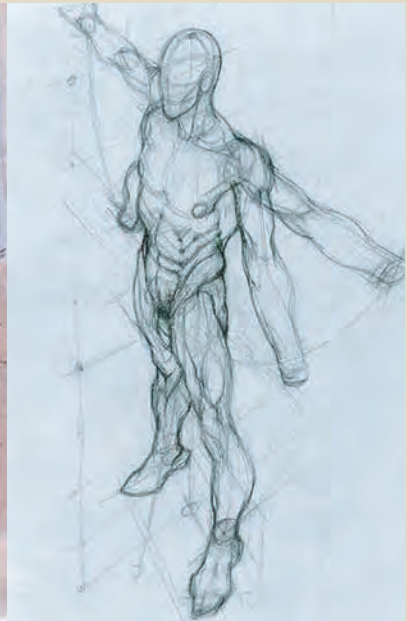
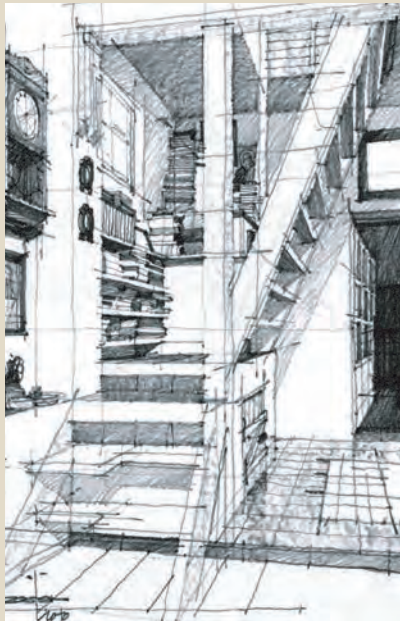





# artWORK book

*artWORK book* is perfect for drafting sketches and designs in the studio or outside in the open. This notebook for sketches is made from high-quality paper that supports a wide range of artists' tools and offers an optimal resistance to erasers. Every *artWORK book* transforms itself into an archive of your works of art and has the following characteristics:

- 128 blank pages "SKETCH" in 160 gram paper, 32 dotted pages "DESIGN" in 120 gram paper, and 32 pages of semi-transparent pages "SHARED IDEAS" in 95 gram tracing paper that is perforated and detachable.

Developed for professionals and for anyone with a passion for art, *artWORK book* leaves space to observations and to the imagination to create sketches and designs from your world.

## FORMATS

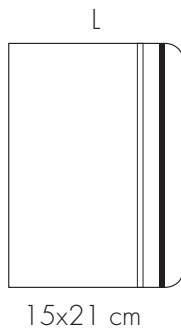

15x21 cm

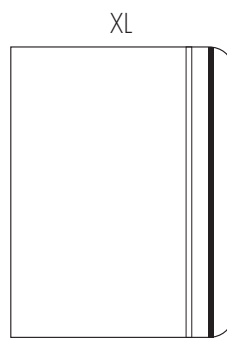

19x25 cm

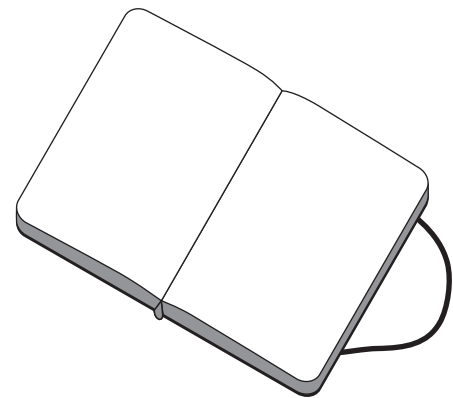

**COMPLETELY OPENS**  
*at 180°*

## DISPLAYS

Supplied already assembled, they are made in white alveolar cardboard, and painted with sprayed tempera in line with the standards of environmental sustainability and respect for the environment.



EXPO2M artWORK

Counter display (15x21 cm)  
**Measurements:** cm 52x29x34h  
**Can contain:** 24 pieces 15x21 cm



EXPO4 ML artWORK

Counter display (15x21 cm and 19x25 cm)  
**Measurements:** cm 56x29x34h  
**Can contain:** 16 pieces 15x21 cm and 8 pieces 19x25 cm





# ARTWORK BOOK 15x21

NOTEBOOK FOR SKETCHES



# ARTWORK BOOK 15x21

NOTEBOOK FOR SKETCHES



# ARTWORK BOOK 19x25

NOTEBOOK FOR SKETCHES





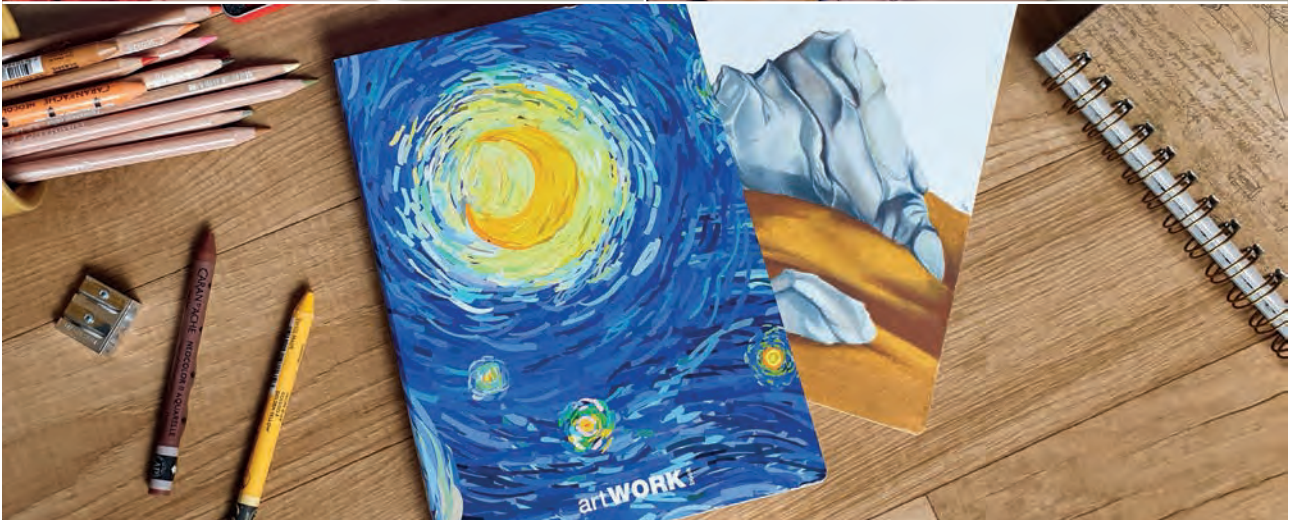

artwork and photograph by Sebastian Łapot @sebastian\_rysuję

# artWORK<sup>pad</sup>

The new *artWORK pad* collection was developed to gather your ideas and projects in a practical solution. Made with the best raw materials that will give an added touch to your creativity.

**SKETCH - DRAW - PAINT :** Made with fine grain drawing paper (weight in grams 120/160/250) whose surface assures easy and repeated erasure and an excellent outcome of your work. Produced with pure cellulose, it's internally sized as well as on the surface and it is acid-free guaranteeing that it lasts over a long period of time.

**WATERCOLOR :** High-quality watercolor paper. It presents itself with a textured surface on both sides that allows it to be used on the front as well as on the back. Produced with the purest cellulose and 40% cotton, it's internally sized as well as on the surface assuring an optimal absorption of colors and the possibility of retouching by washing it with a brush or scraping. It is acid-free assuring a long preservation over time.

**MARKER :** Extra white and an ultra-smooth surface with matte finish specifically made for every type of marker including alcohol and solvent-based markers. It is also suitable for the use of graphite and colored pencils. The paper has a special barrier that prevents colors from passing through and it offers a vivid reproduction of the colors even after repeated use of the marker, sharp strokes, perfect flow of the marker and dries fast. Acid-free.

**MANGA :** The white paper has the same characteristics of the MARKER collection. The 10 sheets in colored paper in five shades allow for the creation of works with brilliant, pearlescent and iridescent surfaces that evoke a Manga style.

**PASTEL :** A special paper made for pastel techniques with a very rough surface that allows for the multiplication of layers of pigment with a saturation effect. It is suitable for energetic strokes as well as for soft shading. In addition, it maintains its properties even after being wet or erased. It also supports wet techniques or alcohol without ruining the grain or the absorption of the surface. It is acid-free with a neutral pH that allows for the perfect preservation over time.

## FORMAT

### SPIRAL BOUND



24x33 cm ●

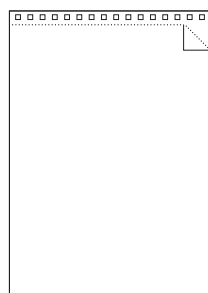

Microperforated

## DISPLAY

Supplied already assembled, it is made in white alveolar cardboard, and painted with sprayed tempera in line with the standards of environmental sustainability and respect for the environment.



### EXPO5 artWORK

Counter display (24x33 cm)

**Measurements:** cm 29x27x40h

**Can contain:** 12 pieces 24x33 cm





# SKETCH

**BEST FOR:** GRAPHITE PENCIL - CHARCOAL - INK - MARKER - FELTTIP PEN - COLORED PENCIL

SMOOTH SURFACE

120 g/m<sup>2</sup>

x80 Sheets  
Natural White

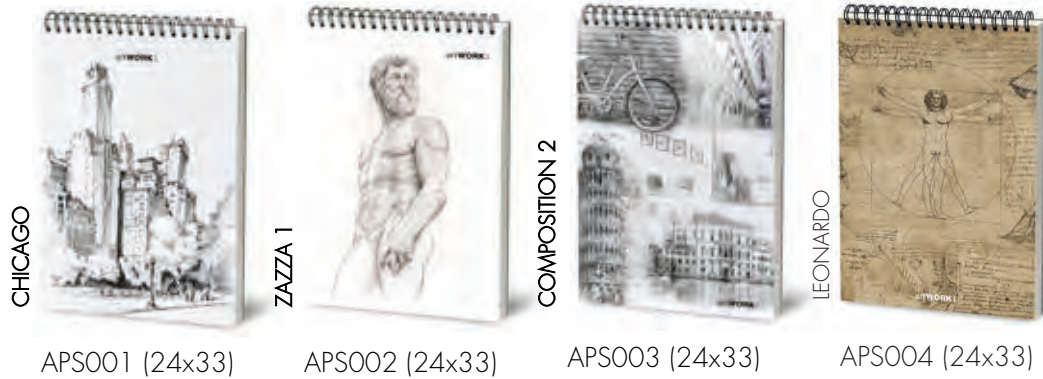

# DRAW

**BEST FOR:** MIXED MEDIA - GRAPHITE PENCIL - CHARCOAL - PASTEL - COLORED PENCIL - CRAYON - FOUNTAIN PEN - INK

SMOOTH SURFACE

160 g/m<sup>2</sup>

x50 Sheets  
Natural White  
+ x15 Sheets  
Transparent



# PAINT

**BEST FOR:** MIXED MEDIA - GRAPHITE PENCIL - GOUACHE - WATERCOLOR - PASTEL - MARKER - FELTTIP PEN

SMOOTH SURFACE

250 g/m<sup>2</sup>

x30 Sheets  
Natural White  
+ x3 Sheets  
Apricot  
+ x3 Sheets  
Light Blue  
+ x3 Sheets  
Light Gray  
+ x3 Sheets  
Black





# WATERCOLOR

**BEST FOR:** WATERCOLOR - INK - GOUACHE - GRAPHITE - CHARCOAL - WAX CRAYON - OIL PASTEL - TEXTURED SURFACE

TEXTURED SURFACE

300 g/m<sup>2</sup>

x20 Sheets  
Natural White



# MARKER

**BEST FOR:** MARKER - FELT-TIP PEN - SPRAY - GRAPHITE - PENCIL - PASTEL

ULTRA SMOOTH SURFACE

300 g/m<sup>2</sup>

x30 Sheets  
Extra White



# MANGA

**BEST FOR:** MARKER - FELT-TIP PEN - SPRAY - GRAPHITE - PENCIL - PASTEL

SMOOTH SURFACE

300 g/m<sup>2</sup>

x20 Sheets  
Extra White

+ x2 Sheets  
White Pearl

+ x2 Sheets  
Cream Pearl

+ x2 Sheets  
Light Green Pearl

+ x2 Sheets  
Light Blue Pearl

+ x2 Sheets  
Pink Pearl







# PASTEL - dark grey

**BEST FOR:** PASTELS - COLORED PENCILS

VERY ROUGH SURFACE

360 g/m<sup>2</sup>

x16 Sheets Dark Grey



# PASTEL - light shades

**BEST FOR:** PASTELS - COLORED PENCILS

VERY ROUGH SURFACE

360 g/m<sup>2</sup>

x16 Sheets Light Shades

+ x4 Sheets Light Grey

+ x4 Sheets Light Blue

+ x4 Sheets Light Green

+ x4 Sheets Apricot



# PASTEL - dark shades

**BEST FOR:** PASTELS - COLORED PENCILS

VERY ROUGH SURFACE

360 g/m<sup>2</sup>

x16 Sheets Dark Shades

+ x4 Sheets Dark Grey

+ x4 Sheets Dark Blue

+ x4 Sheets Dark Green

+ x4 Sheets Dark Red





# artWORK **block**

The *artWORK* collection expands with a new line called **artWORK block**.

Sheets glued on the short side that are easily detachable and a front and back cover in cardstock.

Available in two versions, BRISTOL SMOOTH and BRISTOL ROUGH with the following characteristics:

- BRISTOL SMOOTH, consisting of 50 natural white sheets of 200 grams. The paper has a smooth finish and is made of 35% cotton fibers that makes it ideal for techniques that require a smooth surface and precise strokes like from a pencil, pastels and crayons as well as wet techniques like gouache and watercolor.
- BRISTOL ROUGH, made of 50 sheets of 200 grams in pure virgin cellulose paper of the highest quality. The rough surface, the high level of brightness and the excellent resistance to light combined with a superior rigidity make it a product specifically for dry techniques like pencil, graphite, pastel as well as for wet techniques like watercolor and acrylic paint.

## FORMAT

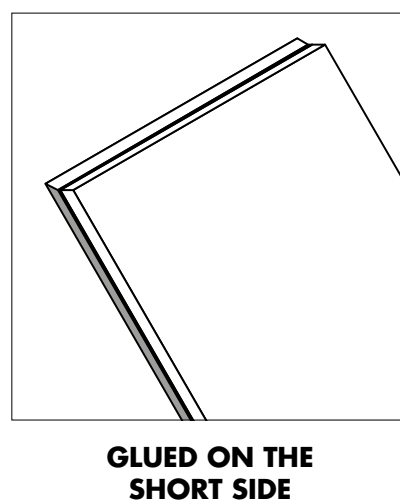
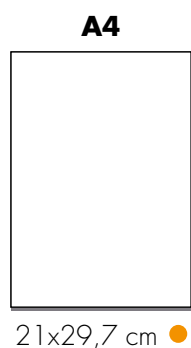



# BRISTOL SMOOTH

**BEST FOR:** MIXED MEDIA - PENCIL - PASTEL -  
WAX PASTELS - GOUACHE - WATERCOLOR

SMOOTH  
SURFACE

200 g/m<sup>2</sup>

 x50 Sheets  
Natural White

	<b>New!</b>	<b>New!</b>	<b>New!</b>	<b>New!</b>
URBAN TRAIN		ART MAKES PEOPLE POWERFUL		URBAN 2 CW
		CARAVAGGIO PORTRAIT		
	ABBLO01 (21x29,7)	ABBLO02 (21x29,7)	ABBLO03 (21x29,7)	ABBLO04 (21x29,7)

# BRISTOL ROUGH

**BEST FOR:** MIXED MEDIA - PENCIL - GRAPHITE -  
PASTEL - WATERCOLOR - ACRYLIC PAINT

ROUGH  
SURFACE

200 g/m<sup>2</sup>

 x50 Sheets  
Extra White

	<b>New!</b>	<b>New!</b>	<b>New!</b>	<b>New!</b>
BARBERINI		CHERUBINI		CENACOLO
		PARIS		
	ABBRO01 (21x29,7)	ABBRO02 (21x29,7)	ABBRO03 (21x29,7)	ABBRO04 (21x29,7)

MADE IN ITALY



1214 RIVER HWY UNIT G, MOORESVILLE, NC 28117, TOLL-FREE 866-833-7797, FAX 888-423-0036  
**CREATIVEARTMATERIALS.COM, ORANGEART.COM**